

DATA SHEET

IEC BELL HOUSINGS AND FLEXIBLE COUPLERS



**Bell Housing
Models:**

76IEC132.15FR, 76IEC180.15FR

**Flexible Coupler
Models:**

8384, 8385, 8386

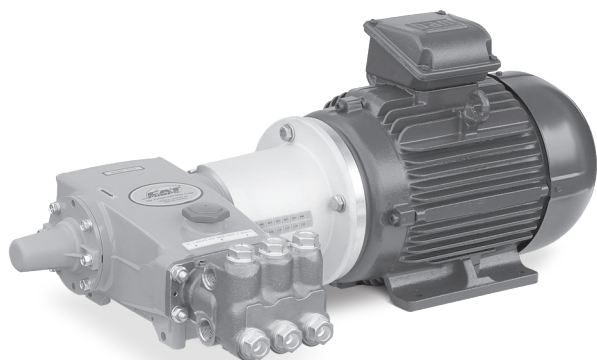

Bell Housing Assembly and Flexible Coupler Assembly
(Model 660 and electric motor sold separately)

FEATURES

- Bell housing design eliminates the need for belt selection, sizing and adjustments.
- Creates optimal shaft alignment, which reduces side-loading for quiet, trouble-free operation.
- Bell Housing is cast from lightweight, high-strength aluminum alloy.
- Compact direct mounting design reduces the space required compared to belt or gearbox drive assemblies.
- Ease of assembly reduces fabrication costs.
- Available as a completely assembled unit from Cat Pumps for fast and convenient assembly, or as individual components.
- Designed to fit 15 and 18 Frame pumps.

PART NUMBERS

Bell Housing Assemblies

Pump Series	Motor Frame	Part Number
All 15FR & 18FR Pumps	132IEC	76IEC132.15FR
	160IEC-180IEC	76IEC180.15FR

Bell Housing Assemblies include bell housing, flange adapter, protective covers, and mounting hardware.

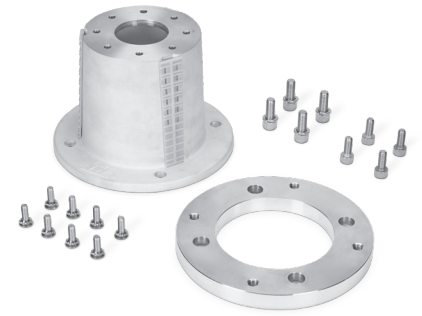

76IEC132.15FR Bell Housing Assembly Shown



76IEC180.15FR Bell Housing Assembly Shown

PARTS LIST

Flex Coupler Assemblies

	8384	8385	8386
Motor Frame	132IEC	160IEC	180IEC
Shaft to Shaft Dimensions	M30 to M38	M30 to M42	M30 to M48
Coupler Half, Motor	996695	996696	996697
Coupler Half, Pump	996672	996692	996692
Pump shaft Key	8 mm	8 mm	8 mm
Key, Pump	990036	990036	990036
Spyder	31544	996694	996694
Spyder (Color)	Purple	Purple	Purple
Torque Rating	203 N-m	305 N-m	305 N-m

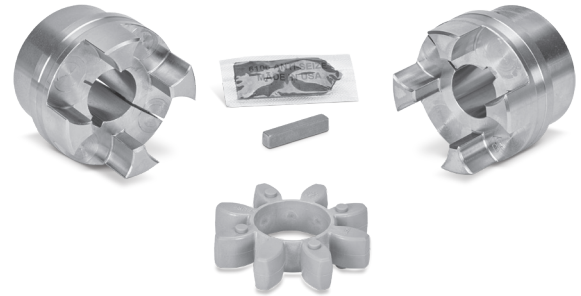

8384 Coupler Shown

INSTALLATION

Bell Housing and Flexible Coupler

1. Separate the parts included in the bell housing and/or flexible coupler assembly packages. Both assemblies are offered in separate kits to cover the various torque ratings and pump models.
2. Remove the bearing cover screws from the extended shaft side of the pump and discard the screws. New screws are supplied in the bell housing assembly.
3. From the side where the bearing cover screws are removed, slide the small end of the bell housing over the pump shaft with the Cat Pumps logo facing up and positioned 22° from the top.
4. Install conical lock washers. Apply Loctite® 242® to the threads of the screws provided in the assembly and torque to 115 in-lbs, 13 N-m for M8 screws in an alternating rotation.
5. Apply a light film of anti-seize lubricant to the pump shaft.
6. Install key into pump shaft.
7. Separate 30mm half of the flexible coupler with the spyder.
8. Remove one (1) cross-clamp screw from the 30mm coupler half. Apply Loctite® 242® to the threads and then reinstall into the coupler half.
9. Slide the 30mm coupler half onto the pump shaft. Align inner face of the coupler flush with the end of the crankshaft.
10. Insert a 6mm or 8mm hex wrench into the cross-clamp screw and tighten enough to hold the key and coupler in place. Tighten this screw to torque specifications in the final step.
11. On the IEC 132 frame bell housing assemblies, mount the flange adapter with the raised and finished surface away from the motor. Apply Loctite® 242® to the threads of the four (4) M10 screws and torque to 180 in-lbs, 20 N-m. Go to step 14.
12. On the IEC 160/180 frame bell housing assemblies, mount the flange adapter with the raised and finished surface away from the motor. Apply Loctite® 242® to the threads of the four (4) M16 screws and install through offset holes on the flange adapter and motor flange.
13. Install four (4) lock washers onto the M16 screws. Hand thread four (4) M16 nuts onto the screws and torque to 1200 in-lbs, 136 N-m.
14. Apply a light film of anti-seize lubricant to the motor shaft.
15. Install the motor key (supplied with motor) onto the motor shaft keyway.
16. Remove one (1) cross-clamp screw from the motor coupler and apply Loctite® 242® to the threads of the screw and then reinstall into coupler half.
17. Slide the motor half of the flexible coupler containing the spyder onto the motor shaft.
18. Mount the pump with the bell housing and coupler half onto the coupler half of the motor, lining up the two halves.
19. Apply Loctite® 242® to the threaded area of the bolts, slip lock washers onto bolts and thread through the flange into the motor. Torque to 300 in-lbs, 34 N-m for M12 bolts.
20. To secure flexible coupling with cross-clamp screws, insert a screwdriver into the bell housing and press the flexible coupler towards the pump.
Note: Flexible coupler halves should not contact each other. Ensure there is a small gap between the two coupler halves.
21. Rotate the motor shaft so clamping screws are lined up with bell housing opening.
22. Insert a 6mm or 8 mm hex wrench into each clamping screw and torque to 300 in-lbs, 34 N-m for M8 cross-clamp screws, or 600 in-lbs, 68 N-m for M10 cross-clamp screws.
23. Install yellow protector covers into each bell housing slot. Trim to fit.

Loctite and 242 are registered trademarks of the Henkel Corporation.

Torque Specifications Chart

Screw	Thread Size	Tool	in-lbs	ft-lbs	N-m
Bell Housing to Pump	M8	5mm Hex Wrench	115	9.6	13
Bell Housing to Flange Adapter	M12	10mm Hex Wrench	300	25	34
Flange Adapter to Motor (76IEC132.15FR)	M10	8mm Hex Wrench	180	15	20
Flange Adapter to Motor (76IEC180.15FR)	M16	24mm Combination Wrench	1200	100	136
Flexible Coupler Cross-Clamp Screw	M8	6mm Hex Wrench	300	25	34
	M10	8mm Hex Wrench	600	50	68

DIMENSIONAL DRAWINGS

Bell Housing Assemblies

Model	Motor Frame	A	ØB	QTY	C (BC)	ØD	QTY	E (BC)	ØF
76IEC132.15FR	IEC132	169.5mm	11.0mm	4	165mm	8.5mm	8	105 mm	130mm
76IEC180.15FR	IEC160, IEC180	202mm	20.0mm	4	300mm	8.5mm	8	105mm	250mm

76IEC132.15FR

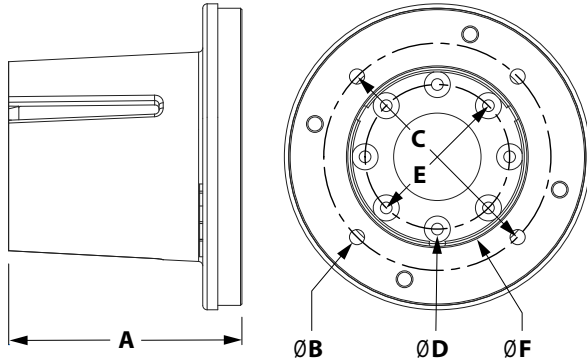

76IEC180.15FR

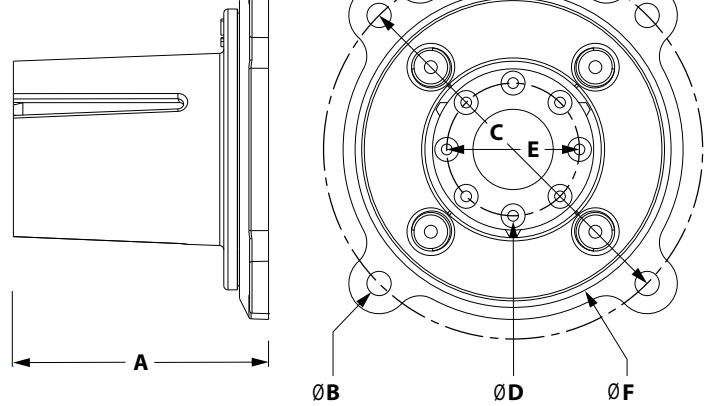

Flexible Coupler Assemblies

Model	ØA	B	C	D
8384	80mm	112mm	22mm	45mm
8385	95mm	126mm	26mm	50mm
8386	95mm	126mm	26mm	50mm

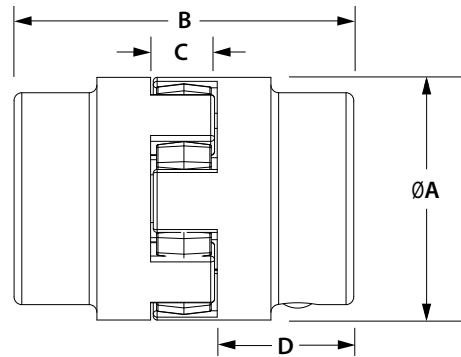
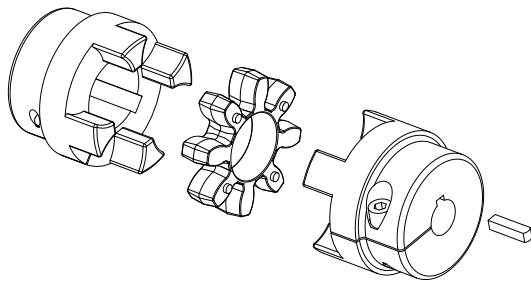

⚠ CAUTIONS AND WARNINGS

All high-pressure systems require a primary pressure regulating device (e.g. regulator, unloader) and a secondary pressure relief device (e.g. pop-off valve, relief valve). Failure to install such relief devices could result in personal injury or damage to pump or property. Cat Pumps does not assume any liability or responsibility for the operation of a customer's high-pressure system. Read all CAUTIONS and WARNINGS before commencing service or operation of any high-pressure system. The CAUTIONS and WARNINGS are included in each Service Manual and with each Accessory Data sheet. CAUTIONS and WARNINGS can also be viewed online at www.catpumps.com/dynamic-literature/cautions-and-warnings or can be requested directly from Cat Pumps.

WARRANTY

View the Limited Warranty online at www.catpumps.com/literature/cat-pumps-limited-warranty